

NOTE: ALL MATERIAL COMPLIANT ROHS STANDARD

REVISION INFORMATION			
Rev.	Rev. Date	Modified By	Brief Description
A0	2016.2.18	LM	C6 UTP 24AWG PANEL TO RJ45
A1	2016.7.15	LM	ADD THE SIZE OF SCREW
A2	2016.8.01	LM	ADD THE SIZE OF MOLD

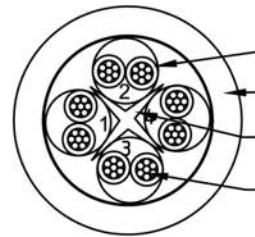
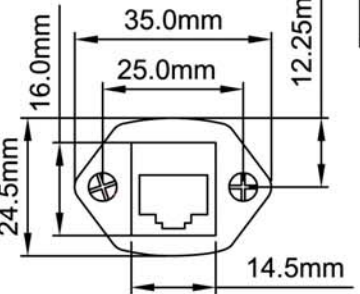
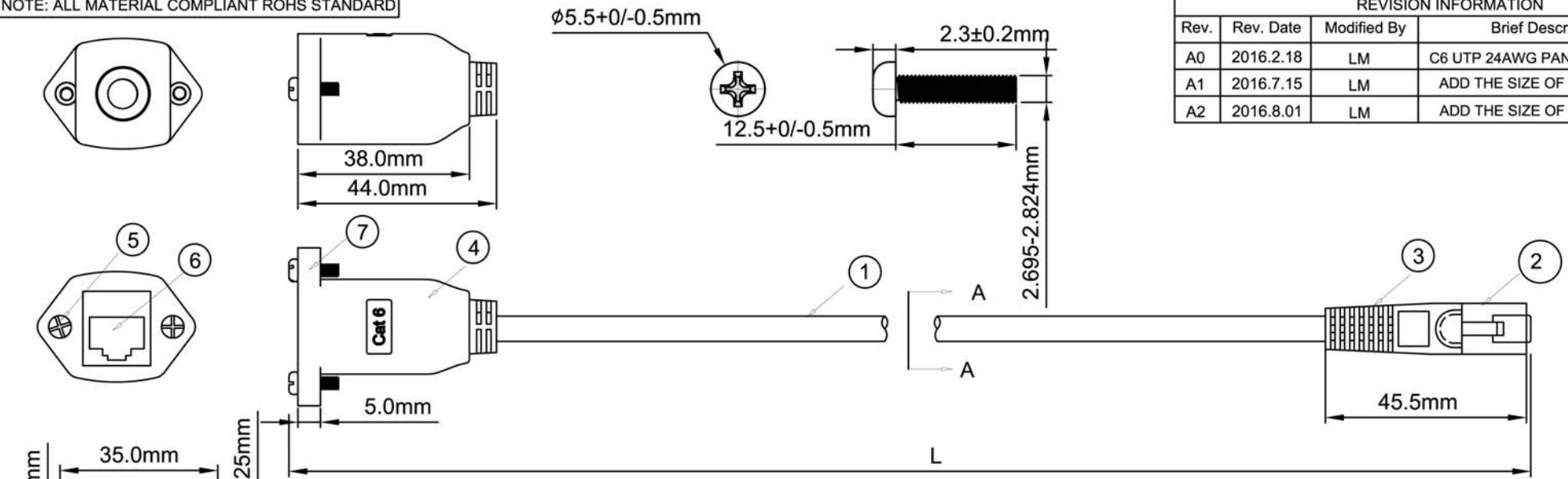

INSULATION:HDPE
 JACKET:PVC OD=6.0±0.5mm
 FILLER:PE
 CONDUCTOR:[24AWG(7/0.196±0.008mm) BC]X4P

Length(FT)	Tolerance(mm)
1	25
2	50
3	50
4	50
6	100
10	100
15	150
25	150

SUGGESTION:
 THE PLUG IS BEST TO BE MOLDED.

PACKING&NOTE:
 1.WITH CLEAR POLIBAG INDIVIDUALLY
 2.BY 10 FOR 1FT,2FT,3FT LENGTHS
 3.ASSEMBLY PASSES CAT6 CHANNEL TEST.
 USING FLUKE OR SIMILAR TEST EQUIPMENT

SEC:A-A

orange 1	green 2
white/orange	white/green
blue 3	brown 4
white/blue	white/brown

NO.	PART NAME	SPECIFICATION DESCRIPTION	QTY	UNIT
⑦	NUT	UNC #4-40 NUT,EMBEDDED,ELECTROPLATE	2	PCS
⑥	JACK	C6 JACK,WHITE HOUSING	1	PCS
⑤	SCREW	SCREW ,PAN-HEAD,UNC #4-40,5/16"(8mm) THREAD,0.3925"(12mm) LENGTH,ELECTROPLATE	2	PCS
④	MOLD	PLASTIC OVERMOLD WITH STRAIN RELIEF,BU608 (3015U) PVC,HARD:60-70P	1	PCS
③	MOLD	PVC YUS-07 BU608 (3015U)	1	PCS
②	PLUG	C6 RJ45 PLUG MALE TRANSPARENT	1	PCS
①	CABLE	C6 UTP 24AWG CM,PRINTING COLOR WHITE,CABLE COLOR BU608 (3015U) PVC	1	PCS

DRAWN BY LM	DATE: 2016/08/01	DESCRIPTION: C6 UTP 24AWG PANEL TO RJ45
CHECKED BY JZY	SHEET 1 of 1	ITEM NO. CAT6-PM-XX
APPROVED BY LANDER	SCALE 1:1	REV. 00 UNIT: mm