

P1: M-003
P2,P3: M-005
P4: M-008

Customer No.: No.1

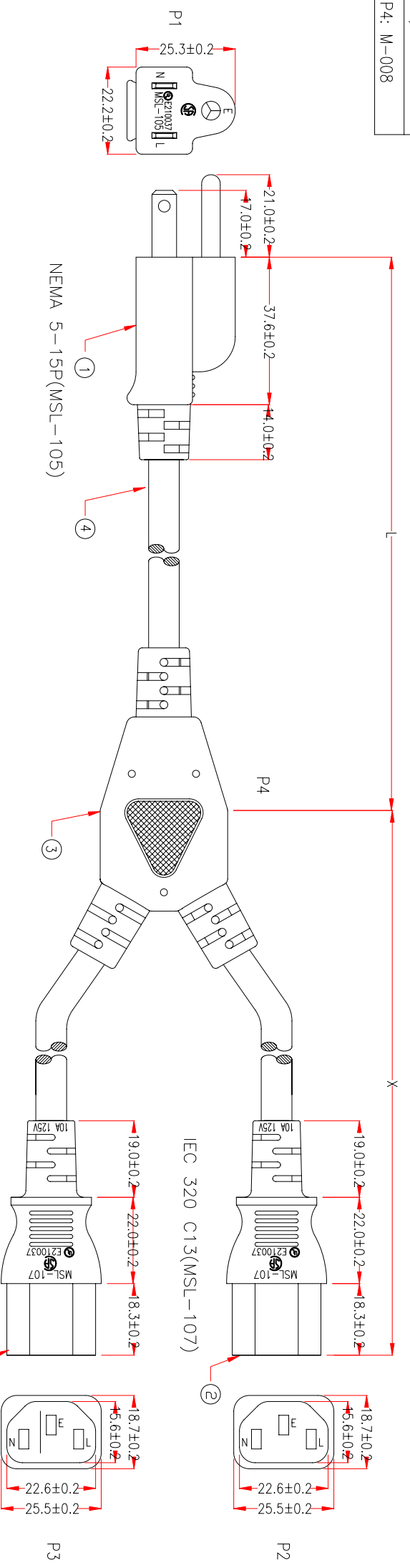

P/N	Length(L)	Length(X)
10W1-185P13Y-03	737mm	178mm
10W1-185P13Y-06	1220mm	610mm
10W1-185P13Y-10	2438mm	610mm

PACKING:

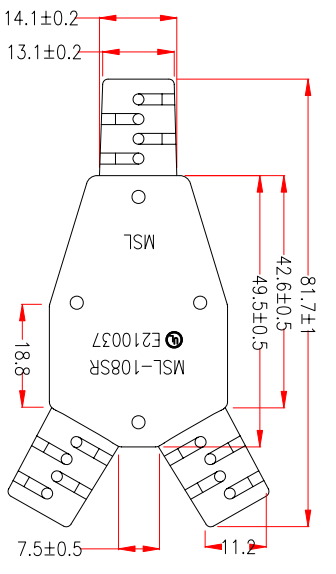
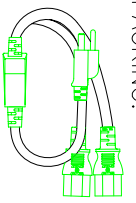

MARKING:
(UL) SUT 3/C 18AWG(0.824MM²) VW-1 75°C 300V E204978
CSA SUT 3/C 0.824MM²(18AWG) FT2 60°C 300V 204790 MSL

P1	P2	P3
BLACK L	L	L
WHITE N	N	N
GREEN E	E	N

*NOTE: All relevant materials are complied with RoHS directive .

P1,P2,P3: E210037
P4: E210037

No.	DESCRIPTION	QTY	Supplier
1	UL SUT 18AWG x 3C, OD 7.8mm, JACKET BLACK, DRAWING No. EPSVT011803C-010	1	M257
2	MOULDED PVC 35P, COLOR BLACK	6	M257
3	BRACKET: YS-021	2	M767
4	TERMINAL: 96146BS-0	3	M257
5	MOULDED PVC 35P, COLOR BLACK	2	M304
6	BRACKET: YS-003	2	M767
7	TERMINAL: 2*4mm, 98744BS-0/A	6	M257
8	MOULDED PVC 35P, COLOR BLACK	1	M304
9	BRACKET: YS-002	1	M767
10	TERMINAL: 98661BS-1	2	M257
11	TERMINAL: 4.75mm, 98475BS-1	1	M257

APPROVED: HU

CHECKED: HU

DRAWING: LIU

13/MAY/16

DRAWN NAME: DRAWN NAME

PRODUCT NO.: P7B1-YY-XX

13/MAY/16

Unless Otherwise Spec. Tolerances: 0, ±0.5, ±0.3, ±0.1

UNIT: mm

