

Customer No.: No.1

P1: M-005B
 P2: M-Y087A
 M-087A
 P3: M-087B

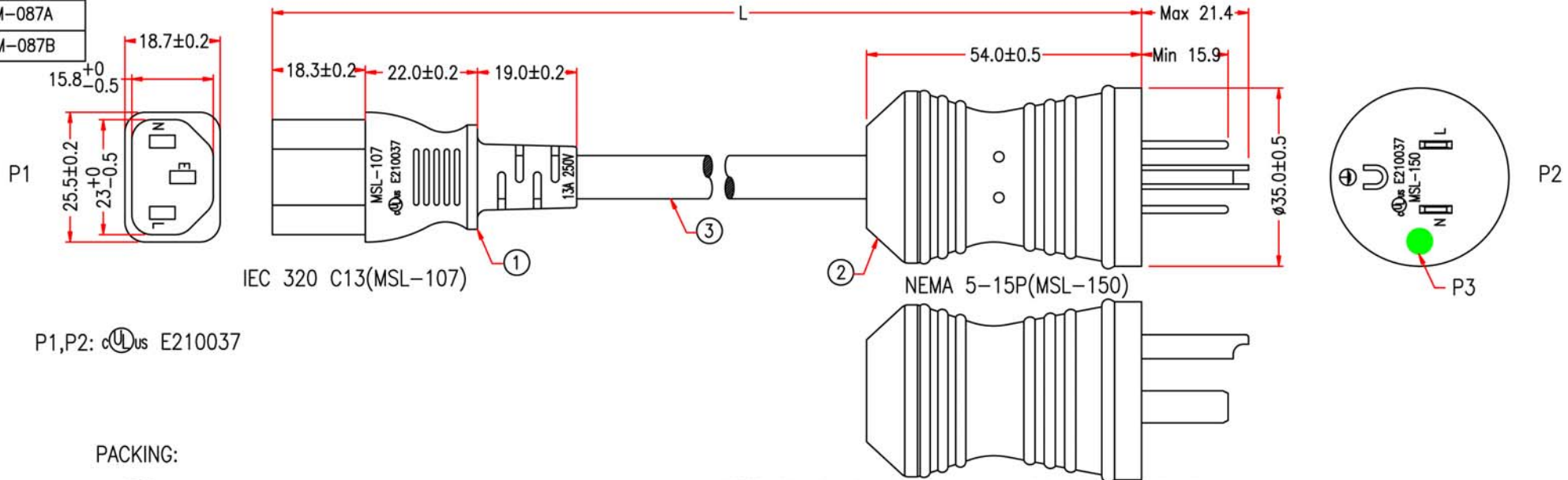

P1,P2: cULus E210037

PACKING:

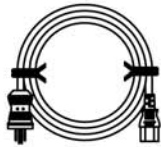

ITEM NO.	LENGTH(L)	LENGTH(X)
P7HG-16AWG-BK-03	915mm	895mm
P7HG-16AWG-BK-06	1830mm	1810mm
P7HG-16AWG-BK-10	3048mm	3030mm
P7HG-16AWG-BK-15	4572mm	4550mm
P7HG-16AWG-BK-25	7620mm	7600mm

CABLE MARKING:

(UL) SJT 3/C 16AWG(1.31MM²) VW-1 105°C 300V E204978
 CSA SJT 3/C 1.31MM²(16AWG) FT2 105°C 300V 204790 MSL

107150B2F16B(FP326-01)			
	P1		P2
BLACK	L	_____	L
WHITE	N	_____	N
GREEN	E	_____	E

NOTE: All relevant materials are complied with RoHS directive .
 THE CABLE MARKING IS CONCAVE LETTERING MOULD

No.	DESCRIPTION	Q'TY	Supplier
3	UL SJT 16AWG x 3C, OD 8.5mm, JACKET BLACK, DRAWING No. EPSVT011603C-059	Xmm	M304
2	MOLDED PVC 80P, COLOR GREEN		M304
	MOLDED PVC 45P, COLOR BLACK (外模)		M304
	MOLDED PVC 35P, COLOR BLACK (内模)		M304
	RIVETING CLAW (脚爪)	1	M1220
1	TERMINAL: 98478BL-1	1	M257
	TERMINAL: 98693BL-1	2	M257
	TERMINAL: 2*4mm, 98744BS-0/A	3	M257

APPROVED	2021.03.17	<p>SFCable 1-888-275-8755</p>	Cable Length Unless Other Spec. Tolerances: 0 ~200mm ±10mm 201~1000mm ±20mm 1001 ~1500mm ±25mm 1501~2100mm ±30mm 2100mm↑ ±40mm
CHECKED	THU		
DESIGNER	JIANG		
DRAWING	ZHU		
DATE	17/MAR/21		
ITEM NO.	P7HG-16AWG-BK-XX	UNIT:mm	

NOTE: Cable Length Unless Otherwise Spec. Tolerances: Under 6FT ±25mm; Another ±50mm