

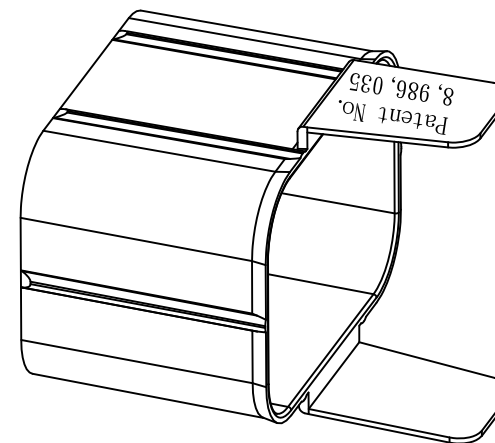

VIEW: A-A

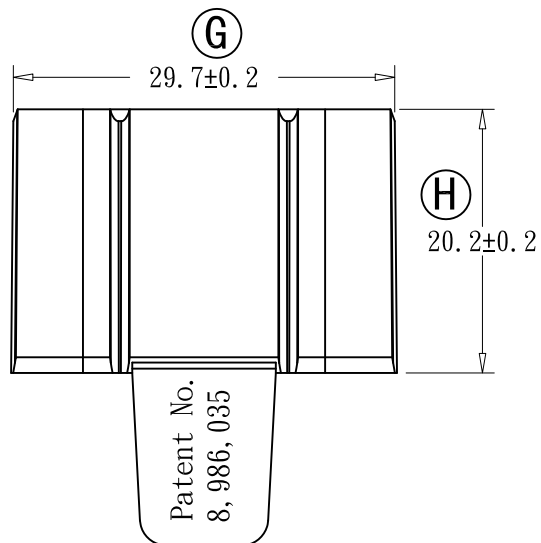

NO.	SPECIFICATION	QTY	REMARK
1	C19 PA66 Nylon Sleeve, black	IPC	

Tolerance >0±0.30 >1.0±0.50 >10.0±1.0 >20.0±2.0 Angle: ±1°	Approved		Date					
	Checked		Date					
	Drawn		Date		Customer			
	Cat. No.	YC-18(C19) SLEEVE			P/N.			
	Drawing No.	CY-N0150	Rev.	B	Material	PA66	Unit	mm
				HEFT(g)		